

 Catler®

the Boss™

Instructions for use
ELECTRONIC BLENDER



BL 9010

**ELECTRONIC
BLENDER**
the Boss™

CONTENT

5	Catler recommends safety first
10	Know your blender BL 9010
13	Operating your blender BL 9010
17	Hints and tips
21	Care and cleaning
24	Trouble-shooting guide



Congratulation

on the purchase of your new blender Catler Catler BL 9010.

Catler

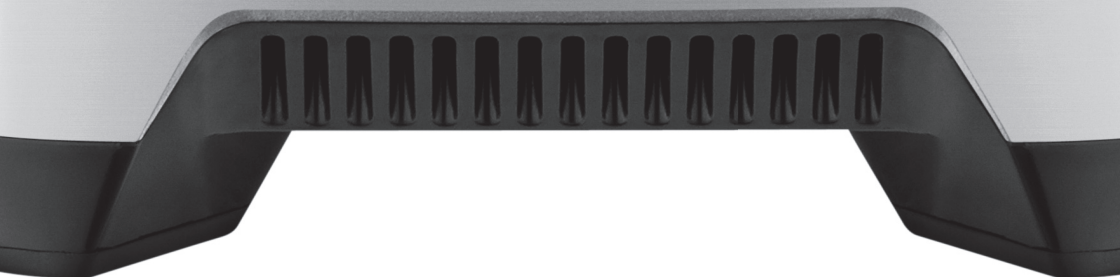

CATLER RECOMMENDS SAFETY FIRST

We at Catler are very safety conscious. We design and manufacture consumer products with the safety of you, our valued customer, foremost in mind. In addition, we ask that you exercise a degree of care when using any electrical appliance and adhere to the following precautions:

IMPORTANT SAFEGUARDS FOR YOUR BLENDER BL 9010

READ ALL INSTRUCTIONS BEFORE USE AND SAVE FOR FUTURE REFERENCE.

- Remove any packaging material and promotional stickers before using the device for the first time.
- To eliminate a choking hazard for young children, remove and safely discard the protective cover fitted to the power plug of this appliance.
- Do not place the blender near the edge of a bench or table during operation. Ensure that the surface is level, clean and free of water, flour, etc. Vibration during operation may cause the appliance to move.
- Do not place the blender on or near a hot gas or electric burner, or where it could touch a heated oven.
- Always ensure the blender is properly assembled before use. Lid must be firmly secured to the jug before operation to ensure internal contents do not escape, spray or overflow.
- Use only the blender jug and lid supplied with the blender. The use of attachments, including canning jars or accessories not manufactured or specified by manufacturer may cause the risk of fire, electrical shock or injury.
- Do not leave the blender unattended when in use.

- Always ensure the blender is turned off by pressing the 'Power' button on the control panel. Then switch the appliance off at the power outlet and unplug the cord. Make sure the motor and blades have completely stopped before attempting to move the appliance, or when the blender is not in use and before disassembling, cleaning and storing.
- Do not operate the appliance continuously with heavy loads for more than 10 seconds. Allow the motor to rest for 1 minute between each use.
- If food becomes lodged around the blending blade, turn the blender off by pressing the POWER button on the control panel. Then switch the appliance off at the power outlet and unplug the cord. Make sure the motor and blades have completely stopped before removing the jug from the motor base. Use a spatula to dislodge or stir the food before continuing. Do not use fingers as the blades are sharp.
- Keep hands, fingers, hair, clothing as well as spatulas and other utensils away from the blender jug during operation. Never place your fingers, hands or utensils inside the blender jug without unplugging the appliance from the power outlet.
- Be careful when handling the jug as the blades are very sharp. Be careful when emptying the blender jug and during cleaning. Mishandling of the blades may cause injury.
- To reduce the risk of severe injury to persons or damage to the blender, keep hands and utensils out of the jug while blending. The scraper and frozen dessert wand provided can be used, provided the main lid is in place.
- Do not remove the blender jug from the motor base while in operation.
- The blender is intended for food and drinks preparation. Do not use for anything other than food or drinks. Do not operate without any ingredients in the blender jug.

- Do not process hot or boiling liquids. Allow to cool before placing into the blender jug.
- Be careful if hot liquid is poured into the blender, as it can be ejected out of the jug due to sudden steaming.
- When blending hot liquids ensure inner measuring cap is in place. Cap will protect from splashing of hot liquids during blending and includes vents designed to relieve pressure and avoid steam build up.
- Be careful removing the lid after blending hot liquids, as steam traps can form in the liquid and be ejected out of the jug.
- Do not subject the blender jug to extremes of hot or cold, for example, placing a cold jug in hot water or vice versa.
- Before moving the blender, cleaning or putting it away for storage, always turn blender off and unplug at the wall.
- Flashing control indicates the appliance is ready to use. Avoid contact with blades and moving parts.
- Never attempt to operate with damaged blades, or with utensils, or any foreign objects inside the blender jug.

IMPORTANT SAFEGUARDS FOR ALL ELECTRICAL APPLIANCES

- The appliance is for household use only. Do not use it in moving vehicles or boats, do not use it outdoors, and do not use it for anything other than its intended use. Misuse can cause injury.
- This appliance shall not be used by children. Keep the appliance and its cord out of reach of children.
- This appliance can be used by children 8 years of age and older and persons with the reduced physical, sensory and mental capabilities or lack of experience and knowledge if they have been given supervision or instruction concerning use of the appliance in a safe way and if they understand the hazards involved. Children must not play with the appliance. Cleaning and maintenance performed by the user must not be performed by children unless they are older than 8 years and under supervision.
- Children younger than 8 years of age must be kept away from the appliance and its power cord.
- Do not allow the cord to hang over the edge of a table or bench, touch hot surfaces or become knotted.
- To protect against electric shock, do not immerse the cord, plug or motor base in water or any other liquid.
- The installation of a residual current device (safety switch) is recommended to provide additional safety protection when using electrical appliances. It is advisable that a safety switch with a rated residual operating current not exceeding 30mA be installed in the electrical circuit supplying the appliance. See your electrician for professional advice.
- In order to avoid the possible hazard of the blender starting by itself due to inadvertent resetting of the overload protector on the motor, do not attach an external switching

- device (such as a timer) or connect the blender to a circuit that can regularly switch the blender on and off.
- Do not operate the blender with a damaged cord or plug, or after appliance malfunctions, or if dropped or damaged in any way. Stop use immediately and contact Catler customer service by phone or email for replacement or repair.
 - Any maintenance other than cleaning should be performed at an authorized service center.
 - It is recommended to regularly inspect the appliance. Do not use the appliance if the power supply cord, plug or appliance becomes damaged in any way. Return the entire appliance to the nearest authorized service center for examination and/or repair.

WARNING:

**DO NOT OPERATE THE APPLIANCE ON AN INCLINED SURFACE.
DO NOT MOVE THE APPLIANCE WHILE IT IS SWITCHED ON.**

WARNING:

**THE POWER PLUG WHEN PLUGGED MUST REMAIN ACCESSIBLE
FOR EASY REMOVING.**

WARNING:

**HOUSEHOLD USE ONLY.
DO NOT IMMERSE TO ANY LIQUID.
FULLY UNWIND THE POWER CORD BEFORE THE USE.**



CAUTION: HOT SURFACE.



SAVE THESE INSTRUCTIONS

Know your
blender BL 9010

KNOW YOUR BLENDER BL 9010

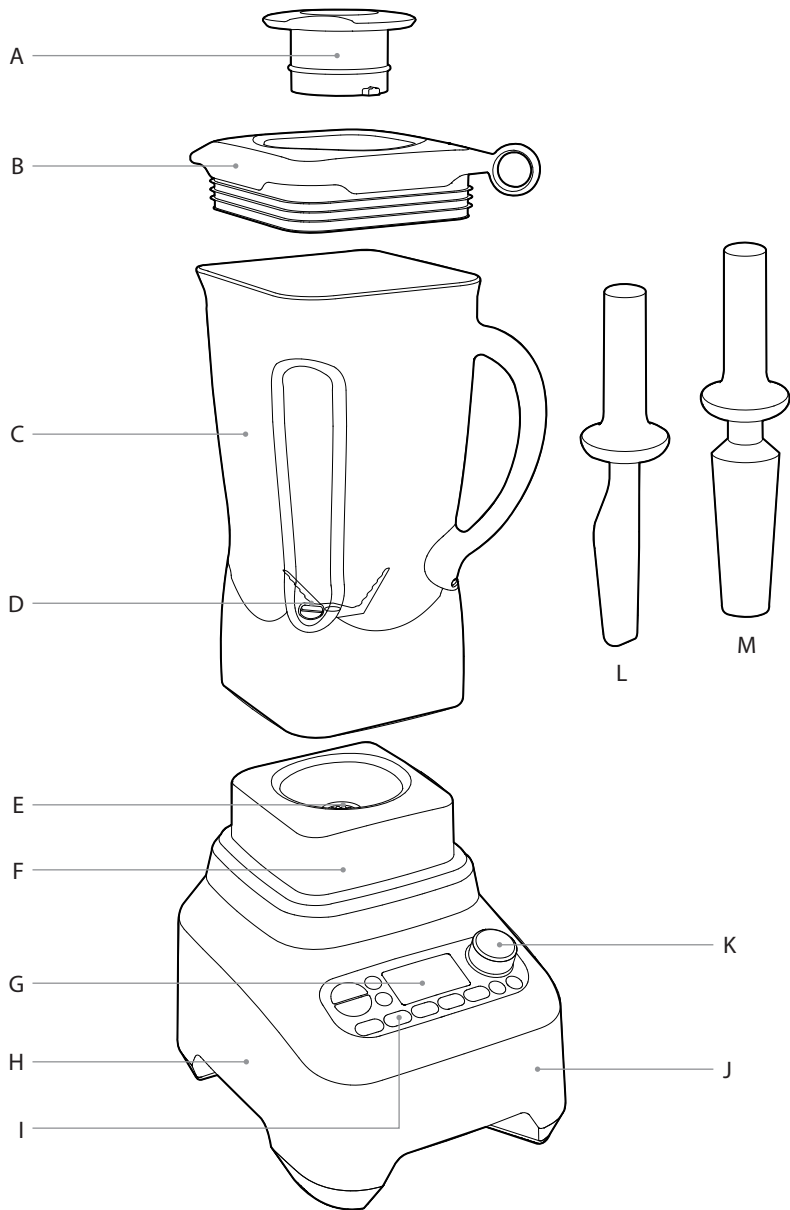

A. Inner measuring cup

Remove to add ingredients while blending.

B. High performance lid

Withstands high velocity tasks, and is designed to vent steam and prevent splatter.

C. 2.0 Litre BPA-free Tritan™ jug

Impact resistant, shatter proof and dishwasher safe.

D. ProKinetix® extra-wide, heavy duty blade and bowl system

Designed with 3 powerful stainless steel blades contoured to the base of the jug for maximum cutting power and processing results including liquid-free processing. The wide blades create the Kinetix® motion, and eliminate food traps.

E. Heavy duty metal coupling

For durable and long lasting performance under demanding conditions.

F. Heavy duty 2200W motor

High velocity power combined with high torque for outstanding results.

G. LCD timer

Counts down for pre-programmed settings, and counts up for speed dial settings.

H. Manual speed control

Wide speed range from super slow stir up to high speed milling for precise control.

I. 5 preset programs

Optimise the blender's capabilities for crushing ice, smoothies, green smoothies, frozen dessert and soup.

J. Overload protection

Resettable thermal fuse for motor protection.

K. Durable die-cast metal base

ACCESSORIES

L. Scraper

Designed to push food down from the walls, or for easily removing ingredients after blending.

M. Frozen Dessert Tamper

Helps make frozen desserts by pushing thick foods directly into the blades.

EASTMAN TRITAN™ COPOLYESTER

This blender jug is made with Eastman Tritan™ copolyester, which is a tough, BPA-free polymer used to make housewares products that can stand up to extreme use and repeated dishwasher cleaning. Products made from Tritan™ are impact resistant and shatter resistant and stay clear and durable even after hundreds of cycles in the dishwasher.

Operating your blender BL 9010

OPERATING YOUR BLENDER BL 9010

Before turning on the blender ensure the lid is firmly secured and inner lid is properly inserted in the main lid. In no cases turn on the blender without firmly secured lid.

Be careful removing the inner lid. In no cases remove the inner lid if processing boiling or hot ingredients. You risk not only splashing out of the jar, but also you can burn yourself of the escaping steam.



GETTING STARTED

ON / OFF

The ON/OFF button is used to turn on the appliance and set to the ready mode and to turn off the appliance. After pressing and at ready mode, the ON/OFF button will flash.

Ready mode – “READY” on the display

The default operation is manual. Using the manual speed control, you start the blender operation to the desired speed. The time will count up on the display and START/CANCEL button will flash. To get back to Ready mode, turn the manual speed control back to the Ready mode – “READY” will be shown on the display.

MANUAL FEATURES

Speed control dial

There are 12 speed settings from STIR through to MILL.

STIR mixes more delicate foods with a slow stirring motion and light pausing to fold ingredients together.

MILL is the fastest setting, and is ideal for milling nuts, grains and seeds.

The blender is programmed to allow manual speeds to run for 6 minutes before automatically stopping.

NOTE:

If you press START/CANCEL button at the Ready mode (“READY” is displayed), the blender will not start.

PAUSE | PLAY

Pauses and holds the speed and timer for up to 2 minutes. Press PAUSE | PLAY once to pause the blender operation, the button PAUSE | PLAY will flash and the display will show "PAUSED", press the button PAUSE | PLAY again to resume the operation.

However, if you press START/CANCEL button, the operation will be cancelled.

Pause is also activated if the jug is removed from base during use. Replace jug, and press START/CANCEL to resume the operation.

Repeat function

It is used for a quick food processing.

Using the manual speed control set up the desired speed, the display will count up the time. Press START/CANCEL button, the display will show the last set-up speed and ON/OFF and START/CANCEL buttons will flash.

If you press START/CANCEL button within 2 minutes, the blender will operate at the last set up speed, the speed on the display.

You can repeat it on and on.

If you want to delete the last set up speed, press and hold START/CANCEL button for about 2 seconds until the display shows "READY".

You will also delete the feature if the manual speed control is turned back to "READY" mode.

Sleep mode

After 2 minutes of inactivity, LCD powers off, and the ON | OFF button flashes red.

After 5 minutes of inactivity, the blender turns OFF completely. Press the ON | OFF button to reactivate.

Up/Down buttons

These are used to set up the timer.

Count-up timer

If the timer isn't set, the blender timer counts up in seconds as it blends. When using the timer this way, the blender will stop after 6 minutes, or you can cancel blending manually.

Count-down timer

The alternative to running the blender in count-up mode is to set the blending time before starting.

PRESET PROGRAMS

All preset programs can be started by pressing their buttons. To cancel the preset program press START/CANCEL button. You can also cancel the program by turning the manual speed control.

Provide these operations only and entirely if necessary. Excessive motor switching can damage the product.

PULSE/ICE CRUSH

Optimised to crush ice, and has an intelligent sensor to stop the motor when ice is done. This cycle is also ideal for processing other foods that need sudden bursts of power.

SMOOTHIE

Optimised to combine and aerate frozen and liquid ingredients together. The SMOOTHIE function has a unique processing technique that blends the denser ingredients at lower speed, then increases in speed as ingredients thicken. This will happen several times while blending smoothies. The programming also circulates the ingredients for maximum aeration and a creamy texture.

GREEN SMOOTHIE

Optimised to break down whole hard ingredients like fruits, leafy greens and seeds, and allows them to blend together with other soft and liquid ingredients.

FROZEN DESSERT

Optimised to break down and combine frozen ingredients quickly. Use the frozen dessert tamper for best results.

SOUP

This preset program blends and heats ingredients to make soups. The program has a slow start to combine ingredients before running at high speed, and ends with a couple of stirs to release any steam bubbles that may have formed in the soup.

Do not process raw meats or seafood using the SOUP function.

WARNING:

If a lot of steam is formed, or steam bubbles explode at SOUP function, immediately stop the blender operation. Wait 30 seconds before removing the lid. Do not process food for more than 2 soups.

WARNING:

Never blend boiling hot liquids. Allow temperature to drop before putting into the jug for blending.

AUTO CLEAN

Use to remove most of the ingredients off the blender walls and blades. Add 500ml warm water and a drop of detergent, and press the AUTO CLEAN button. For harder to clean, sticky or thick ingredients, add 1/2 teaspoon of dish liquid detergent for extra cleaning power. For best results, run the clean cycle immediately after use.

WARNING:

Wait for blender to stop before lifting jug. Always ensure the lid is firmly secured.

Hint and tips

HINTS AND TIPS

- If the volume (while blending) is below the maximum line, the inner measuring cap can be removed and oils/liquids can be added while blender is in use.
- Run the blender only for the appropriate amount of time required – do not over blend ingredients.
- Use the PULSE | ICE CRUSH button when food is too thick or coarse to circulate within the blender jug.
- The scraper and frozen dessert tamper accessories can be used during blending by removing the inner measuring cap. Always make sure the main lid stays firmly in place.
- Do not exceed the maximum mark when adding foods and liquids into the blender.
- Ingredients may stick to the sides of the blender jug. To push food back onto the blades with the main lid on (inner cap removed), use the scraper provided to scrape down the sides of the jug, and continue blending.
- If any moisture or liquid appears on top of the motor base during blending, turn the blender off and unplug from the outlet. Remove the blender jug, and wipe motor base immediately with a dry cloth or paper towel.
- The maximum amount of ice cubes that the blender can process is 250g (approx. 1 standard ice tray).
- When the blender has been running for 6 minutes in manual mode, it will automatically turn off. This is a safety feature to protect the motor.
- Thicker mixtures puree more efficiently if the jug is $\frac{1}{4}$ to $\frac{1}{2}$ full.
- Do not use metal utensils, as they may damage the blades or blender jug.
- Dates and other dried fruits may vary in hardness and moisture content. If adding dried fruits to smoothies, use the tamper for the first 15-20 seconds of the SMOOTHIE or GREEN SMOOTHIE setting.
- To make nut milks, add 1-2 cups of raw or soaked/drained nuts. Process on CHOP of 15-20 seconds, or until evenly chopped. Soaked nuts may need the scraper spatula to assist movement as the blades chop. Once evenly chopped, add 3-4 cups of purified water, and process on MILL for 2 minutes. Strain through a nut milk bag (or muslin / cheesecloth) over a large bowl or jug. Close bag and squeeze the pulp in the bag to extract as much milk as you can.
- To soak or not to soak nuts? This is a personal preference and you can make nut milks with unsoaked or soaked almonds. Almonds are a great source of protein however they contain a naturally occurring compound that may prevent our enzymes from digesting the nuts effectively. Try soaking nuts overnight to help break down the compound. Always rinse and drain soaked nuts before use.
- Roasting nuts to make nut butter allows their natural oils to be released during blending, and enriches the flavour. Some nuts, such as almonds and hazelnuts, have a lower oil content. Add rice bran, macadamia or coconut oil when blending, if needed.

- Freshly milled whole grain flour does not keep as long as commercial flours. This is because the inner layers of the grain contain rich oils, which can become rancid over time with exposure to heat and moisture. Always store your flour in an airtight container in a cool, dry place. Flour can be stored in the refrigerator or freezer in warm/ humid climates.
- Corn, soy beans and some other dried legumes and grains vary in their moisture content, and may not circulate properly during milling. Use the scraper spatula during milling to assist with circulation.
- To remove any food that cannot easily be scraped out from under the blades, replace lid and turn blender back on high speed for 4-5 seconds to spin foods out from under blades.

Blending chart

FOOD	PREPARATION AND USAGE	QUANTITY	FUNCTION	TIME
Grains and seeds	Mill into flour. Use in bread, pizza doughs, cakes, muffins and flour batters	250 - 500g	MILL speed	30-60 seconds
Dried legumes & corn e.g. Soy beans, chickpeas, popping corn	Mill into flour. Use in combination with plain or self-raising flour for bread, cakes, muffins, pancakes	250 - 500g	MILL speed	1 1/2 - 2 minutes
Spices	To make ground spices. Use whole spices except for cinnamon quills that need to be broken half. Store in airtight containers	55 - 115g 8 - 16 cinnamon sticks	MILL speed	1 minute
Raw nuts	To make nut meal. Use in cakes, biscuits and muffins	150g - 300g	MILL speed	20-30 seconds
Roasted nuts	To make nut butters and spread	300g - 450g	MULL speed, use tamper	1 minute
White sugar	Mill to make pure icing sugar or powdered sugar	200g	MILL speed	15 seconds

Dry milling

Please note that milling hard ingredients like spices, nuts, sugar, coffee, grains, etc. will cause scratching and clouding to the inside surfaces of the jug.

This is a cosmetic result from milling these kinds of ingredients, and does not affect the performance of the jug.

FOOD	PREPARATION AND USAGE	QUANTITY	FUNCTION	TIME
Biscuits/cookies	Break biscuits /cookies in half. Blend to form crumbs. Use for cheesecake crusts	250g	Program PULSE/ICE CRUSH	6-10 pulses
Bread crumbs	Remove crusts. Cut bread into 2 ½ cm cubes. Use in crumb coating, stuffings or in meatballs and meat patties	120 g (up to 3 slices)	CHOP speed	20-30 seconds
Mayonnaise	Mix the egg yolk, mustard and vinegar or lemon juice. Add oil slowly through the lid. Use for dressing	Up to 4 egg yolks and 2 cups of oil	MIX speed	1 min 30 sec
Hard cheeses (like Parmesan and Pecorino)	Cut into 3cm cubes. Use in creamy sauces, pasta dishes	130g	CHOP speed	15-20 seconds
Cream	Whip cream to firm peaks. Add sugar or vanilla before blending if desired	300 - 600 ml	MILL speed	10 seconds
Raw vegetable	Peel and cut into 2cm cubes. Finely chopped. Use for stuffing, filling, Bolognese, stews and casseroles	200g	CHOP speed	5-10 seconds

This blending chart should be used as a guide only.

Care and cleaning

CARE AND CLEANING

Jug and lid

To avoid food drying on blades, jug and lid, follow the below steps as soon as possible after use:

- Rinse most of the ingredients off the jug and lid.
- Add 500ml of warm water and 1–2 drops of detergent and press the AUTO CLEAN button.
- Rinse the jug and lid again and/or wash separately in warm soapy water with a soft cloth or bottle brush.

Sanitising

The recommended sanitising solution is 1 1/2 teaspoons (7.5ml) of household bleach in 8 cups (2 litres) of clean, cool water, mixed according to the recommended instructions on the bleach container.

To sanitise, follow the below steps:

1. After performing the auto clean cycle as per the instructions above, add half (4 cups / 1L) of the recommended sanitizing solution to the jug. Secure the lid and inner lid and press AUTO CLEAN to run a sanitising clean cycle.
2. Allow to stand for 1 minute, then empty solution.
3. Soak lid, inner lid (also scraper spatula and frozen dessert tamper if used) in the remaining second half of the sanitising solution mixture for 2 minutes.
4. Place the empty jug and lid back on blender base and run on manual speed MIX for 10-20 secs to remove any excess moisture from the blade area.
5. Wipe the exterior of the lid, jug and base with a soft cloth dampened with the sanitising solution.

6. Do not rinse after sanitising. Allow to air dry before storage. Rinse with clean water prior to next use.

Motor base

To clean the motor base, wipe with a soft, damp cloth then dry thoroughly. Wipe any excess food particles from the power cord.

Cleaning agents

Do not use abrasive scouring pads or cleaners on either the motor base or the jug, as they may scratch the surface. Use only warm soapy water with a soft cloth.

Dishwasher

The blender jug and lid can be washed in the dishwasher on a standard wash cycle. Jug can be placed on the bottom shelf, however the lid and inner lid should be on the top shelf only.

Stubborn food stains and odours

Strong smelling foods such as garlic and fish, and some vegetables such as carrots, may leave an odour or stain. To remove, clean the jug and lid using the AUTO CLEAN instructions.

Add 2 tablespoons bicarbonate of soda and 1/2 cup (125ml) vinegar into jug and let the mixture froth for 1 minute. Scrub the jug and lid with the mixture using a soft dishwashing brush. Add 2 cups warm water and allow to stand for 5 minutes. Attach jug to blender base. Secure lid and then press the AUTO CLEAN button. Thoroughly rinse the jug, and allow to air dry. Store jug and lid with the lid off to allow air to circulate.

Dry milling

Milling hard ingredients like spices, nuts, sugar, coffee, grains, etc. will cause scratching and clouding to the inside surfaces of the jug.

Some spices and herbs release aromatic oils that may discolour the jug or leave an aroma.

These are cosmetic results from milling these kinds of ingredients, and does not affect the performance of the jug.

Storage

Store your blender upright with the blender jug assembled on the motor base, or beside it. Do not place anything on top. To allow air to circulate, keep the lid off.

WARNING:

Blades are very sharp. Pay higher attention when handling the blender jug. Store the blender out of reach of children.

Trouble-shooting guide

TROUBLE-SHOOTING GUIDE

<p>Motor doesn't start or blade doesn't rotate</p>	<ul style="list-style-type: none"> • Check the blender jug and lid are securely in place. • Check the ON OFF button and selected function button is illuminated. • Check that the power plug is properly inserted into the power outlet.
<p>Food is unevenly chopped</p>	<ul style="list-style-type: none"> • This can happen when too much food is being blended at one time. Try a smaller amount, and work in batches if necessary. • The ingredients may be too large. Try cutting into smaller pieces. For best results, ingredients should be in pieces no larger than 2cm.
<p>Food is chopped too fine or is watery</p>	<ul style="list-style-type: none"> • Try blending for shorter period of time. Use the ICE CRUSH PULSE function for better control.
<p>Food sticks to blade and jug</p>	<ul style="list-style-type: none"> • The mixture may be too thick. Try adding more liquid and/or using a slower speed for blending.
<p>Food stuck under blades</p>	<ul style="list-style-type: none"> • To remove any food that cannot easily be scraped out from under the blades, replace lid and turn blender back on high speed for 4-5 seconds to spin foods out from under blades.
<p>Blender overloaded</p>	<ul style="list-style-type: none"> • This blender has a motor protection feature to protect against overheating and/or over current use. When activated OVERLOAD PROTECTION will flash on the LCD and the blender will be inoperable. • If activated, turn the blender off by pressing the ON OFF button on the control panel, switch of at the wall and unplug the blender. Wait a few minutes then re-plug and power ON the blender. • If OVERLOAD PROTECTION is still flashing, repeat and leave the blender for at least 20-30 minutes. Once OVERLOAD PROTECTION has disappeared from the screen the blender is ready to be used again. • We recommend blending in smaller batches, or cutting ingredients into smaller pieces.

INSTRUCTIONS AND INFORMATION REGARDING THE DISPOSAL OF USED PACKAGING MATERIALS

Dispose of packaging material at a public waste disposal site.

DISPOSAL OF USED ELECTRICAL AND ELECTRONIC APPLIANCES



The meaning of the symbol on the product, its accessory or packaging indicates that this product shall not be treated as household waste. Please, dispose of this product at your applicable collection point for the recycling of electrical & electronic equipment waste. Alternatively in some states of the European Union or other European states you may return your products to your local retailer when buying an equivalent new product. The correct disposal of this product will help save valuable natural resources and help in preventing the potential negative impact on the environment and human health, which could be caused as a result of improper liquidation of waste. Please ask your local authorities or the nearest waste collection centre for further details. The improper disposal of this type of waste may fall subject to national regulations for fines.

For business entities in the European Union

If you wish to dispose of an electrical or electronic device, request the necessary information from your seller or supplier.

Disposal in other countries outside the European Union

If you wish to dispose of this product, request the necessary information about the correct disposal method from local government departments or from your seller.



This product meets all the basic EU regulation requirements that relate to it.

Changes to the text, design and technical specifications may occur without prior notice and we reserve the right to make these changes.

The original version is in the Czech language.

Address of the manufacturer: FAST ČR, a.s., Černokotelská 1621, Říčany CZ-251 01

 Catler®

the Boss™

Due to continued product improvement, the products illustrated/photographed in this brochure may vary slightly from the actual product.



W W W . C A T L E R . E U

CUSTOMER SERVICE

I N F O @ C A T L E R . E U